



Similar to the RPH 53.3 shown here, the RPH 42.2 can be front bumper mounted on high GVW 4x4 utility vehicles.

ADDITIONAL EQUIPMENT & SERVICES

- Air shift freespool clutch with remote activation and positive engagement indicator light.
- Radio control system to give flexibility in operating the winch up to 40m distance.
- Wire Rope – up to 24m (Short Drum) or 36m (Long Drum) x 11mm dia. (1960N/mm² grade) fully galvanised flexible, crush resistant with heavy duty safety hook.
- Heavy duty Electric / pneumatic control valve with manual lever, including 7m wanderlead control, heavy duty 16 amp socket, electrical control system with all wiring in Armaflex protection. Also includes dump valve with emergency stop button ensuring compliance with EU machinery directives.
- Hydraulic oil reservoir tank with filter sight gauge and filler cap, PTO and pump.
- Full or partial fitting can be provided, including load testing and certification.

RAMSEY RPH 42.2 4.3 Tonne Planetary Hydraulic Winch

Commercial Recovery & Load Pulling

This popular machine is perfect when fast line speeds are required, designed to be either foot or side mounted.

The perfect machine for medium to heavy recovery and for front bumper mounting on high GVW 4x4 utility vehicles.

Fully compliant with EN 14492-1 regulations.

FEATURES INCLUDE

- **4300kgf line pull**
Rated line pull of 42.2kN on 1st layer
- **EN 14492-1 compliant**
- **Good recovery speeds**
Up to 12m per minute on 4th layer
- **Bi-rotational drum**
Clockwise and anti-clockwise as required
- **Short drum and long drum options**
165mm or 248mm lengths
- **Large 100mm diameter drum(s) with deep flanges**
Extends rope life and assists wrapping. Flange dia. 220mm
- **Wedge pocket rope anchor on drum**
Major safety benefit - prevents rope release from drum fixing
- **Heavy duty roller guide assembly**
With greaseways and large diameter rollers
- **Suitable for foot or side mounting**
- **Dual braking system**
Mechanical brake and counterbalance valve
- **Weight only 49Kg**
76kg with wire rope, roller guide and mounting kit
- **After sales service**
Technical advice given on winch fitting and component replacement, plus efficient overnight parts despatch and fast repairs.

SECURE WIRE ROPE ANCHORAGE

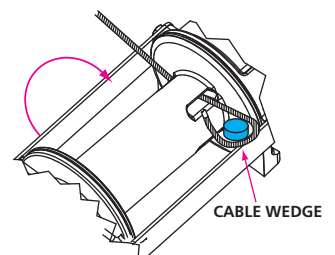

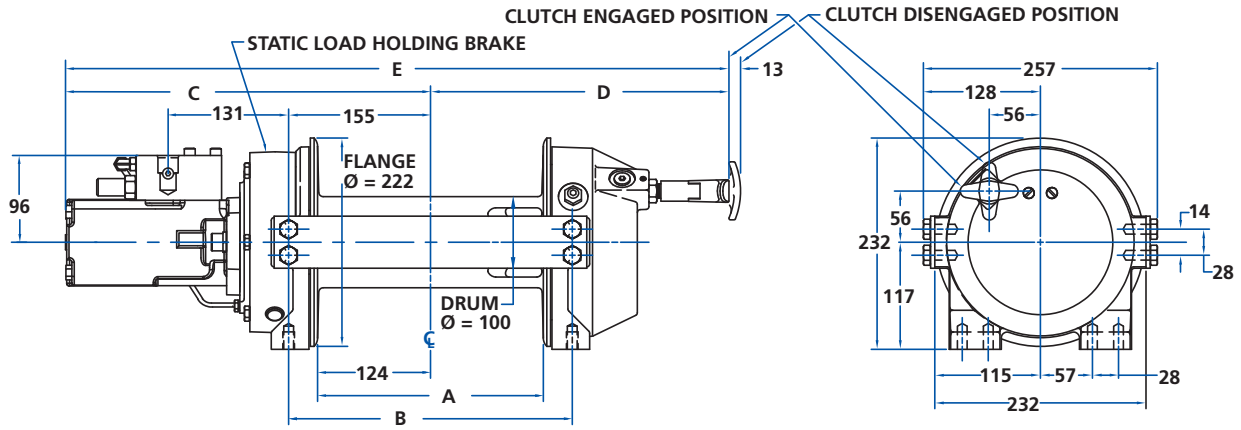

RPH 42.2 DRUM TYPE	A	B	C	D	E
SHORT DRUM	165	229	357	296	643
LONG DRUM	248	311	396	337	726

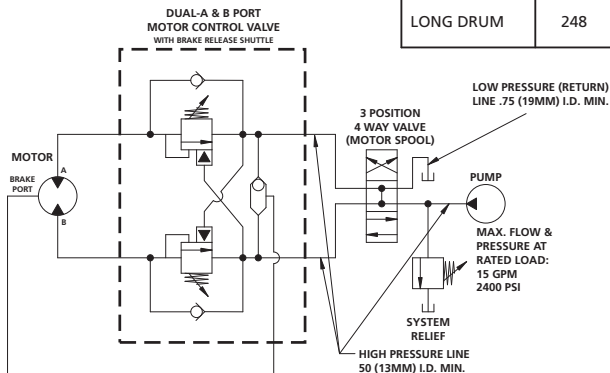

LAYER LONG DRUM				
	1	2	3	4
Maximum Rated Line Pull by Layer	kN 42.2	35.2	30.2	26.4
	kgf 4300	3590	3080	2690
RPH 42.2 Rope Capacity Cumulative by Layer (11mm Dia. Wire Rope)	m 6	15	24	36
*Line Speed at 50 l/min	m/min 8	9	10	12

* Based on recommended 11mm wire rope, 1960N/mm² grade and 408cc / rev. motor.

SPECIFICATIONS

- Rated Line Pull:** 42.2kN (4300kgf). EN 14492-1 compliant
- Line Speed:** 8 m/min at 50 lt/min. on 1st layer, up to 12 m/min. on 4th layer
- Wire Rope Capacity:** 11mm diameter x 24m length (Short drum) and 36m (Long drum) (1960N/mm² grade, 6 x 36 wire core construction - recommended)
- Weight:** Weight of machine: 49kg.
Weight with mounting kit, roller guides and rope: 76kg
- Gear Reduction:** 5.1:1
- Winch Construction:** Die cast aluminium end housings with steel drum
- Braking:** Disc brake and counter balance valve providing full 100% braking
- Motor:** Low speed, high torque. 409cc/rev
- Freespooling:** Spring loaded lever. Option: Air activated clutch using remote switch with engagement indicator light
- Drum:** 100mm diameter x 165mm length (Short drum) or 248mm (Long drum) with wedge pocket rope anchor
Flange diameter 222mm
- Drum Rotation:** Clockwise, or anti-clockwise rotation as required
- Roller Guides:** Heavy duty commercial type with large diameter rollers and greaseways

NOTE: An open centre motor spool type control valve must be used (all ports open to tank in neutral).

NOTES

These winches must not be used for the movement of personnel and 5 wraps of wire rope must be maintained on the drum.

Data shown is approximate and intended as a guide only.

HYDRAULIC PERFORMANCE

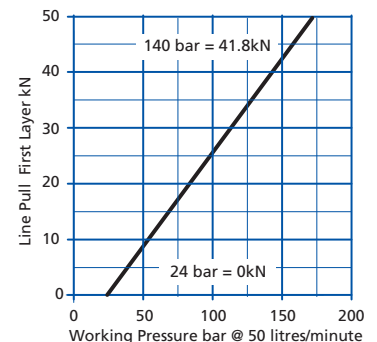
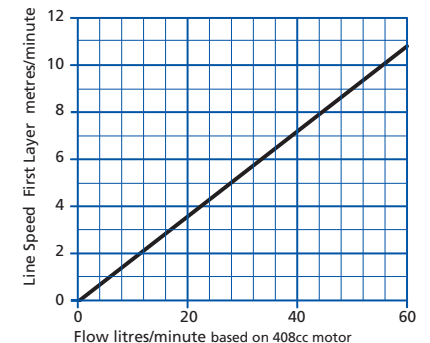

WARRANTY

Each new winch is guaranteed against defects in workmanship and material defects for a period of twelve months from date of purchase.

Wire ropes are not included under warranty.

Bushey Hall Winchmaster sales@bhwwgroup.co.uk www.bhwwgroup.com

Southern Office: Lismirrane Industrial Park, Elstree Road, Elstree, Herts, WD6 3EE Tel: +44 (0)20 8953 6050 Fax: +44 (0)20 8207 5308

Northern Office: 6 South Orbital Trading Park, Hedon Road, Hull, East Yorkshire, HU9 1NJ Tel: +44 (0)1482 223 663 Fax: +44 (0)1482 218 285

Bushey Hall Winchmaster is a division of BHW Group Limited. Registered in England No. 1342461



CERT. No. 1769