

BH DELTA 2250 KIT COMPRISES

Electric Winch, 4.5m heavy duty 2 button wanderlead, mounting plate, roller guides and 8mm x 23m galvanised 1960Nmm² grade 6x36 core wire rope with safety latch hook.

Total kit weight 40kg.



Can also be supplied with:
Emergency Stop, Safety Solenoid
and In-Cab Switch (not shown)

ADDITIONAL EQUIPMENT & SERVICES

- BHW WINCH CONTROL SYSTEM (see below)
- Electric isolator switch
- Auxiliary industrial 16 amp plug and socket kit for wanderlead connection
- Fuse and fuse holder
- Snatch block
- Radio Control Unit
- Full or partial fitting can be provided, including load testing and certification

BH DELTA 2250

12v or 24v DC Electric Recovery Winch 2250kg Line Pull

**Light Duty Car Transporters, Plant Moving
Vehicles with GVW up to 3500kg, Spec-Lifts, 4x4's**

This low profile planetary winch has been developed for light industrial use. It incorporates a large electric motor, ensuring good service life.

FEATURES INCLUDE

- **2250kg line pull**
(22.07kN)
- **Powerful series wound, high torque motor options**
12v or 24v
- **Optional electronic load limiting device**
Pre wired to solenoid for safer winch operation
- **3 stage planetary gearing**
Providing high mechanical efficiency
- **Automatic braking action in drum**
- **Freespool clutch lever**
Easy to operate lever for disengaging drum
- **Power in / power out**
Fine control ensures load will not overrun
- **4 way roller guides and mounting plate**
- **Heavy duty 4.5m wanderlead control**
Two button supplied a standard, alternative lengths and additional emergency stop button available on request
- **Wire rope positively secured to drum**
Using fixed plug and grub screw engagement

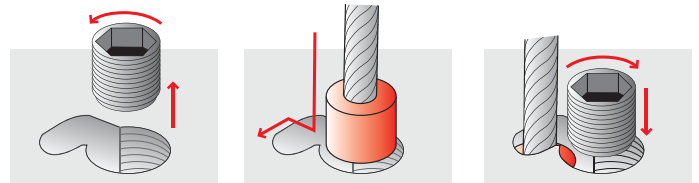

UPGRADE TO A BHW WINCH CONTROL SYSTEM

Save time and money on installation - Ready to fit.

A choice of three alternative winch control kits designed to provide all in one emergency stop, isolator switch, safety solenoid and power outlets.

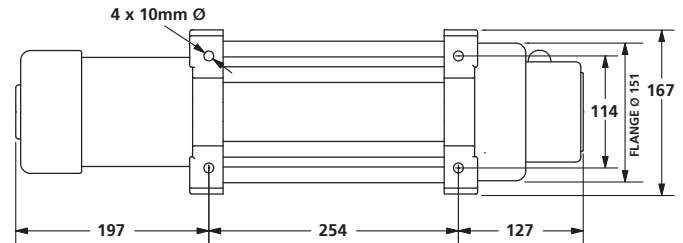
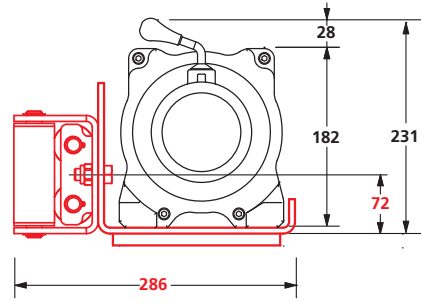
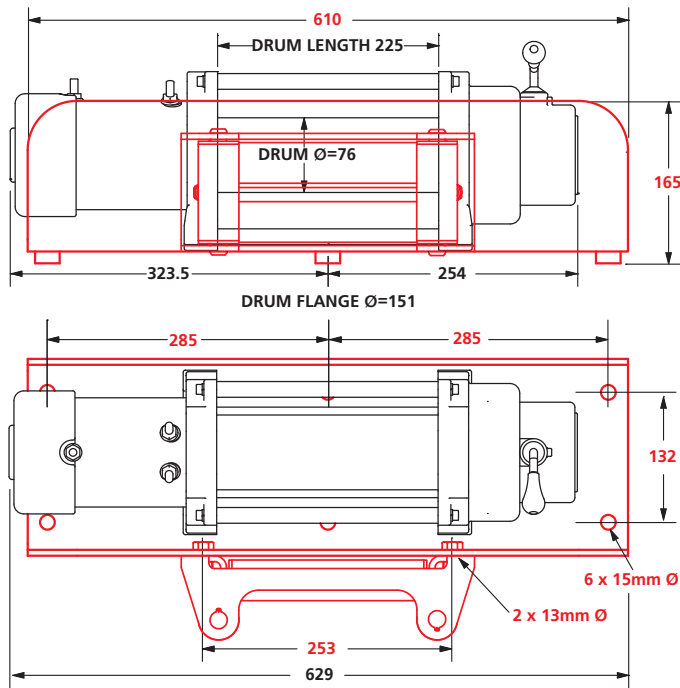

		LAYER		
		1	2	3
Maximum Rated Line Pull by Layer*	kgf	2250	1860	1584
	kN	22.07	18.24	15.53
Cable Drum Capacity Cumulative by Layer (8mm dia. cable)	m	7	15	23

*By incorporating a snatch block in the line it is possible to double these capacities.

PERFORMANCE FIRST LAYER OF CABLE				
LINE PULL kgf	LINE SPEED (approx)		AMP DRAW (approx)	
	12v m/min	24v m/min	12v	24v
0	8	8	66	32
500	6	7	120	60
1000	4.5	5	170	85
1500	4	4.2	204	102
2000	3.2	3.5	240	120
2500	2.6	2.8	280	140

All figures are based on battery maintaining normal voltage.

SPECIFICATIONS

Rated Line Pull (single line): Maximum recommended working capacity 2,200kgf to comply with EN14492-1. Stall capacity 4300kg.

Gear Ratio: 216:1 for either 12v or 24v.

Motor: High torque series wound 12v (6hp) or 24v (4.7hp).

Switching: Heavy duty, double acting solenoids can be mounted adjacent to winch or on to the winch tie bars with straps provided.

Load Limiting Device Optional, pre-wired and fitted to underside of solenoid pack. Can be calibrated to shut down winch when maximum load limit is reached.

Wanderlead Control: Commercial heavy duty type with 2 operating buttons and 4.5m cable. Other lengths and additional emergency stop button versions available on request.

Roller Guides: Heavy duty, 4 way commercial type with greaseways.

Wire Rope: 8mm diameter galvanised 1960Nmm² grade, 6 x 36 wire core construction with 44.7kN minimum breaking strain.

Freespooling: Lever on gear housing to disengage clutch.

Complete Kit Weight: 40kg.

NOTES

These winches must not be used for the movement of personnel and 5 wraps of wire rope must be maintained on the drum.

Data shown is approximate and intended as a guide only.

WARRANTY

Each new winch is guaranteed against defects in workmanship and material defects for a period of twelve months from date of purchase.

Wire ropes are not included under warranty.

Bushey Hall Winchmaster sales@bhwwgroup.co.uk www.bhwwgroup.com

Southern Office: Lismirrane Industrial Park, Elstree Road, Elstree, Herts, WD6 3EE Tel: +44 (0)20 8953 6050 Fax: +44 (0)20 8207 5308

Northern Office: 6 South Orbital Trading Park, Hedon Road, Hull, East Yorkshire, HU9 1NJ Tel: +44 (0)1482 223 663 Fax: +44 (0)1482 218 285

Bushey Hall Winchmaster is a division of BHW Group Limited. Registered in England No. 1342461



CERT. No. 1769