



Spring loaded safety lock is supplied as standard

## NEW EUROPEAN STANDARDS & BHW GROUP

New Harmonised European Standards: EN14492-1 for power driven winches, EN14492-2 for power driven hoists provide the means for conformity to essential Health and Safety requirements of the EC Machinery Directive.

Conformity to these standards is the joint responsibility of the supplier, the installer and the company operating the product.



BHW Group products are fully compliant and carry a CE mark. A Declaration of Conformity is also supplied with each winch or hoist.

Selecting the correct winch or hoist for the application is very important not only from the health and safety aspect, but also to maximise product life and value for money.

Our aim at BHW Group is to ensure the correct machine is supplied to suit the application and we welcome the opportunity of discussing the proposed application and offer advice. It will help us considerably if information regarding the maximum and average loads to be lifted or pulled - and approximate frequency of use can be provided.

For hoisting applications the minimum breaking force (MBF\*\*) of the wire rope must be 5 x the lifting capacity of the hoist. The ratio of wire rope diameter to mean drum diameter\* is usually at least 15:1. This will vary according to the application, the average operating time per day and the average and maximum weights being lifted.

For pulling applications (for example, in factories) as a general rule requires a wire rope with a MBF\*\* relative to winch capacity of 3:1 and a rope to mean drum ratio\* of 12:1.

For recovery vehicles the permissible standard of wire rope MBF\*\* to winch rating can be a minimum 2:1 and the ratio of wire rope to mean drum ratio\* only 10:1. This minimum standard is permitted because the running time is so short and the winch rarely sees maximum load.

Wire rope capacities the maximum amount of wire rope on the drum must leave a freeboard to the top of the drum flange of 1.5 x wire rope diameter to prevent the wire rope coming off the drum.

Winches and hoists with capacities over 1000kg must be load limited.

\* Mean drum diameter = the drum diameter plus the diameter of the wire rope.

\*\* MBF = the Minimum Breaking Force of the wire rope.

Bushey Hall Winchmaster sales@bhwgroup.co.uk www.bhwgroup.com

Southern Office: Lismirrane Industrial Park, Elstree Road, Elstree, Herts, WD6 3EE Tel: +44 (0)20 8953 6050 Fax: +44 (0)20 8207 5308

Northern Office: 6 South Orbital Trading Park, Hedon Road, Hull, East Yorkshire, HU9 1NJ Tel: +44 (0)1482 223 663 Fax: +44 (0)1482 218 285

Bushey Hall Winchmaster is a division of BHW Group Limited. Registered in England No. 1342461

## COMPACT SCAFFOLD HOISTS

CWS-80 (80kg), CWS-160 (160kg),  
CWS-230 (230kg), CWS300 (300kg)

110v or 240v x 1ph AC

### FEATURES INCLUDE

- Available in 110v and 240v x 1ph options  
CWS80 / 160 / 230 = 110v & 240v  
CWS300 = 240v only
- Dynamic and mechanical brake  
Provides instant, safe braking
- Lightweight and compact design  
For easy handling and installation
- Operates on standard 240v household power supply  
In the case of 110v version - via transformer
- Automatic upper and lower limit switch  
When rope disc comes into contact with limit arm, hoisting is automatically stopped
- Supplied complete with wire rope  
Galvanised finish for longer life
- 360° weighted safety hook  
Swivel type with safety catch
- Spring loaded safety lock  
For secure attachment to scaffold
- Motor rating IP44  
Brush type motor
- 10 metre plug in pendant control  
2 button plus emergency stop
- 5 metre power lead with commercial type 3 pin plug

### OPTIONAL EXTRAS

- Jib arm  
Scaffold supported, 180° rotation
- Pendant control extension  
Plug in for additional 10 metre length

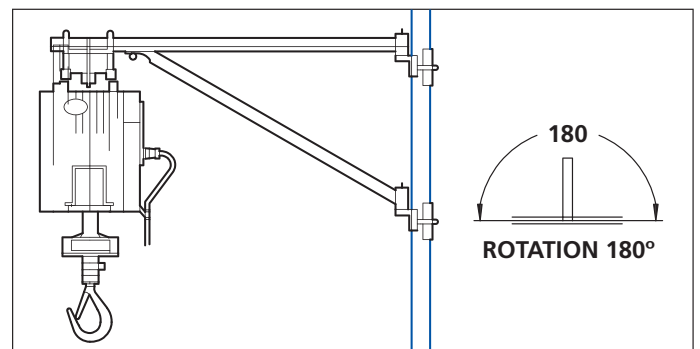

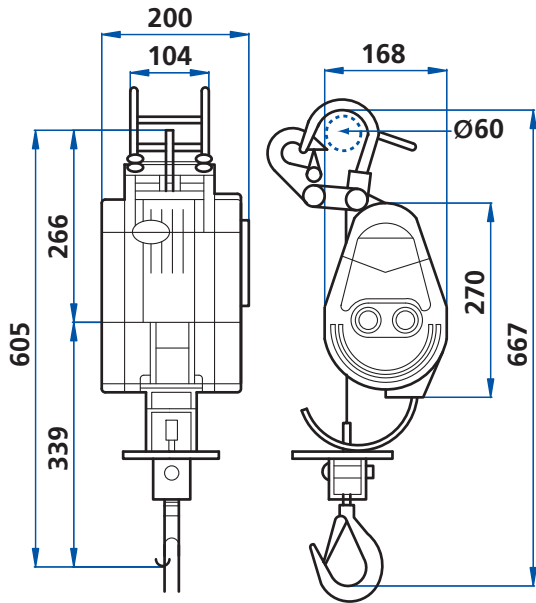
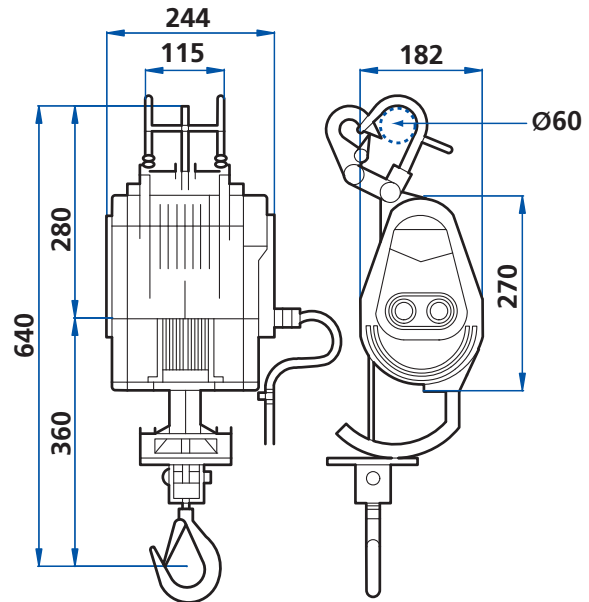
**CWS80****CWS160 / CWS230 / CWS300****SPECIFICATIONS****CWS80****CWS160****CWS230****CWS300**

Voltage:	110v	240v	110v	240v	110v	240v	240v only
Lifting: Capacity	80kg		160kg		230kg		300kg
	23m		30m		24m		24m
Weight: Hoist only	9kg		14kg		15kg		17kg
	18kg		25kg		26kg		28kg
Line speed: 1st layer	18m/min		15m/min		9m/min		9m/min
	30m/min		25m/min		14m/min		13m/min
Duty cycle:	All Scaffold Hoists have a duty cycle of 25%, with a maximum of 60 starts per hour						
Wire rope: Diameter	4mm		5mm		5mm		5mm
	24m		31m		25m		25m
Rope construction	6 x 19 wire core, galvanised for longer rope life. Factor of safety = 5:1						
Motor:	All Scaffold Hoists have a brush type induction motor						
Outputs: Kilowatts	0.8kw		1.2kw		1.3kw		1.5kw
	8amp	4amp	12amp	6amp	13amp	6.5amp	7.5amp
Braking:	Motor: Electronic via resistor				Gears: Mechanical ratchet brake		
Drum: Length	46mm		110mm		110mm		110mm
	70mm		94mm		94mm		94mm
	158mm		155mm		155mm		155mm
Rope $\varnothing$ to mean drum $\varnothing^*$	18:1				20:1		

\* Mean drum diameter = the drum diameter plus the diameter of the wire rope

**NOTES**

Please ensure that the fixing point for these hoists are capable of supporting the loads required.

These hoists must not be used for the movement of personnel and 7 wraps of wire rope must be maintained on the drum.

Data shown is approximate and intended as a guide only.

**WARRANTY**

Each new hoist is guaranteed against defects in workmanship and material defects for a period of twelve months from date of purchase.

Wire ropes are not included under warranty.

**Bushey Hall Winchmaster** sales@bhwwgroup.co.uk www.bhwwgroup.com

**Southern Office:** Lismirrane Industrial Park, Elstree Road, Elstree, Herts, WD6 3EE Tel: +44 (0)20 8953 6050 Fax: +44 (0)20 8207 5308

**Northern Office:** 6 South Orbital Trading Park, Hedon Road, Hull, East Yorkshire, HU9 1NJ Tel: +44 (0)1482 223 663 Fax: +44 (0)1482 218 285

Bushey Hall Winchmaster is a division of BHW Group Limited. Registered in England No. 1342461



CERT. No. 1769

WM24/16.08.11